

MASON SAFETY



TREAD



Lead Filled

Carborundum Filled

AMERICAN MASON SAFETY TREAD CO.

LOWELL, MASSACHUSETTS

R

MASON SAFETY TREAD

THE ORIGINAL, THE BEST AND THE MOST DURABLE

PROTECTION AGAINST SLIPPING

INDEX of CONTENTS

	Page
General Field	2
Uses	2
Cross Sections, Steel Base	3
Cross Sections, Hard Brass Base	4
Brass Nosings	4
Mason Safety Tread on Wood	5-11-14
Mason Safety Tread on Iron	5-12
Mason Safety Tread on Stone	8
Mason Safety Tread on Cement	9-10-15-21
Mason Safety Tread Curved	10-13-15-21
Mason Safety Tread and Cork Composition	11-12-13-14-15
Combination Mats, Mason Safety Tread and Cork Composition	13
Repairing Worn Stairs	13-14
For Steam and Electric Cars	15-16-17-22-23
For Marine Use	18
Mason Safety Vault Lights	19-20
Stanwood Step and Tread	22-23
Karbolith Sanitary Flooring	23
Where Accident Policies do not Insure	24
Specification Forms	24
Some Recent Installations	24

MANUFACTURED BY
AMERICAN MASON SAFETY TREAD COMPANY
Main Offices: LOWELL, MASS.

BOSTON NEW YORK CITY WASHINGTON CHICAGO KANSAS CITY CLEVELAND ST. LOUIS

Branch Offices in
Agents in Large Cities throughout the United States

IN THE MATTER OF SAFETY TREADS THE RECOLLECTION OF QUALITY, SERVICE AND DURABILITY WILL REMAIN LONG AFTER THE PRICE HAS BEEN FORGOTTEN

MASON SAFETY TREAD

Has withstood the test of time, having been on the market for many years, both in Europe and America.

It has earned a reputation for durability and efficiency in tens of thousands of places.

It has won the favor of the best architects and engineers, of public officials, of accident insurance companies, of railroad men, of owners and caretakers of buildings, but, most of all, of the great traveling public.

It has proved itself the best device known for insuring against slipping on stairs, landings, inclined ways, car steps, in fact, in any place that is liable to be slippery.

It has been adopted by many railroads, and is in use in public buildings of all kinds, office buildings, railroad stations, schoolhouses, department stores, hotels, restaurants, factories, and private residences.

It is so constructed as to provide an absolutely safe foothold, and the non-slippery quality is prolonged as long as the tread lasts. It is not a superficial safety surface, but the protective quality is co-extensive with the life of the tread, and it continues effective when worn down, and remains intact and solid as when originally installed.

It has demonstrated beyond question its durability or long life; many of the first treads sold by this company are still in use, and practically as good as when new.

Accident Insurance Companies recognize it as the best surety against accidents, and they not only recommend it, but there have been many instances of their having refused to give insurance unless these treads were used. In cases where accidents on stairways have come before the courts of different states, in the shape of claims for damages, the decision has been invariably in favor of the defendants where Mason Safety Tread was in use. These decisions have been mainly on the ground that where the defendant has used the best known and standard device for prevention of accidents, no negligence could be shown on the part of the defendant; in other words, these accidents have been held to have been caused by the carelessness of the parties sustaining the injuries.

THE USES OF MASON SAFETY TREAD

It may be placed upon outer or inner stairs of granite, marble, slate, cement, iron or wood; upon old, partly worn, as well as new surfaces; upon thresholds of doors and elevators, fire doors, inclined passages, straight or curved, vault light borders, vault entrances, granolithic walks, ship ladders, the steps, running boards, platforms and vestibules of cars, around machinery where the presence of oil is dangerous, in trolley car barn pits, along the edges of platforms, and many other places.

Besides other Federal Buildings where Mason Safety Tread has been installed, are the United States Capitol, the Federal Treasury, the Coast and Geodetic Survey, the Government Printing Office Building at Washington, Post Office and Sub-Treasury at Boston, Post Office, Sub-Treasury, Appraisers' Store and Custom House at New York, Federal Prisons at Atlanta, Ga., and Leavenworth, Kan., at Watervliet Arsenal, Ordnance Building, League Island Navy Yard, Foundry Building at Mare Island Navy Yard, San Francisco, in buildings at the Portsmouth Navy Yard at Kittery, Me., and numerous post offices, including those at Lowell, Mass., Portland, Me., Kansas City, Mo., Minneapolis and St. Paul, Minn., Peoria, Ill., Cleveland, Ohio, Montreal, Can., and other large cities.

MASON SAFETY TREAD

Is composed of rolled, unperforated steel or hard brass (delta metal), with alternate U-shaped and dovetailed grooves, the dovetailed grooves being filled with the non-slippery, soft metal lead or with carborundum grains. Carborundum is an extremely hard and abrasive material, and the grains are securely bound together and to the steel base with a chemical cement.

It is always cleanly, neat in appearance and noiseless in use. There is no mushrooming over of the lead, caused by wear, leaving ragged edges under which filth and germs may collect. There are no rivets, nuts, boltheads or protruding buttons on which clothing can catch and cause damage. The abrasive or non-slippery surface does not wear off and leave a polished, dangerous, slippery, hard metal base exposed to traffic.

Its life must always equal that of the steel walls of the grooves; lead or carborundum filled wear equally long. It is fireproof, and because of its structural form, adds to the cross-sectional strength of stair treads where it is used. It protects the step to the extreme front edge.

Mason Safety Tread is made in steel in one uniform thickness ($\frac{1}{4}$ inch) and six widths, namely, $2\frac{1}{2}$, 4, $4\frac{3}{4}$ and 6 inches flat, and 3 and $3\frac{1}{2}$ inches with nosing.

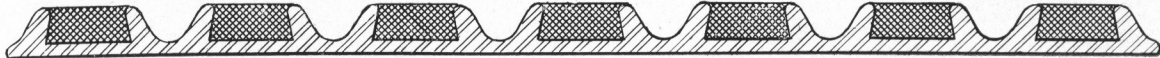

FIG. 1. CROSS SECTION.

Steel, 7 Ribs, 6'' Wide

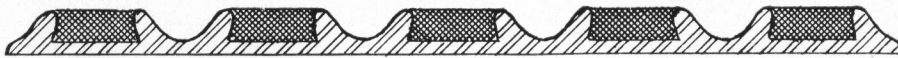

FIG. 2. CROSS SECTION.

Steel, 5 Ribs, $4\frac{3}{4}$ '' Wide

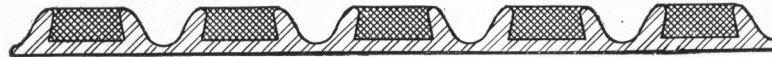

FIG. 3. CROSS SECTION.

Steel, 5 Ribs, 4'' Wide



FIG. 4. CROSS SECTION. Steel, 4 Ribs with Nosing, $3\frac{1}{2}$ '' Wide



FIG. 5. CROSS SECTION. Steel, 3 Ribs, with Nosing, 3'' Wide, Straight Back, Especially Made For Granolithic Work



FIG. 6. CROSS SECTION

Steel, 3 Ribs, $2\frac{1}{2}$ '' Wide

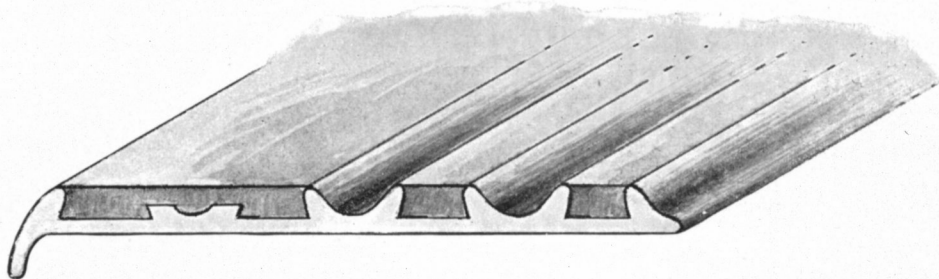
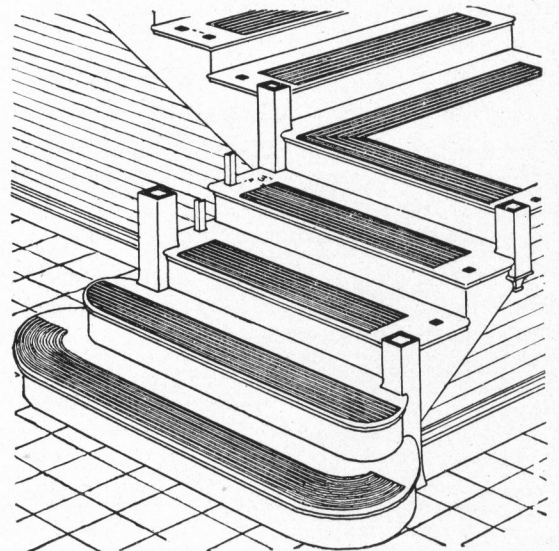

FIG. 17. CROSS SECTION PERSPECTIVE.

Steel, Broad Front Rib, $3\frac{1}{2}$ '' With Nosing



Mason Safety Treads of almost any desired width may be made from our standard widths as indicated above.

The 3-inch nosing piece is intended for use with cork carpet, or for concrete and cement work, as it has a square back edge.

Mason Safety Tread is prepared at our factory according to specifications, punched and countersunk for screws, and can be curved and mitered and cut to any desired length, as indicated in the cut on this page.

MASON SAFETY TREAD WITH BRASS BASE

The hard brass (delta metal) base is durable and absolutely noncorrosive under ordinary conditions of wear, and for this reason is used in the Navy and Merchant Marine. It takes a handsome polish, and is employed extensively on marble stairs, adding to the artistic effect. This is of the same thickness ($\frac{1}{4}$ inch) as the steel base. It is made with short nosing, $2\frac{1}{8}$ and $3\frac{1}{2}$ inches wide; in deep nosing, $2\frac{3}{4}$ inches wide, and in flat, $2\frac{1}{4}$, 3, 4 and 6 inches wide.

Like the steel, the brass base has alternate U and dovetailed grooves, the dovetailed grooves containing lead or carborundum.

Below are cuts of our standard widths of brass (delta metal) base safety treads. **These widths apply only to treads with brass base.**



FIG. 7. CROSS SECTION.

Brass (Delta Metal) Base, 8 Ribs, 6'' Wide



FIG. 8. CROSS SECTION.

Brass (Delta Metal) Base, 5 Ribs, 4'' Wide



FIG. 9. CROSS SECTION.
Brass (Delta Metal) Base, 4 Ribs, 3'' Wide



FIG. 10. CROSS SECTION
Brass (Delta Metal) Base, 3 Ribs, $2\frac{1}{4}$ '' Wide



FIG. 11. CROSS SECTION. Brass (Delta Metal) Base, 4 Ribs, $3\frac{1}{2}$ '' Wide

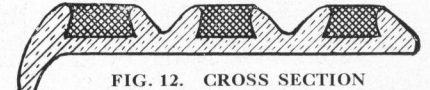

FIG. 12. CROSS SECTION
Brass (Delta Metal) Base, 3 Ribs, $2\frac{1}{4}$ '' Wide

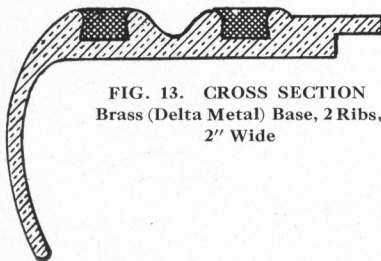

FIG. 13. CROSS SECTION
Brass (Delta Metal) Base, 2 Ribs, 2'' Wide

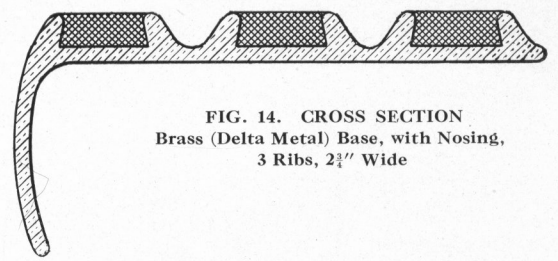

FIG. 14. CROSS SECTION
Brass (Delta Metal) Base, with Nosing, 3 Ribs, $2\frac{1}{4}$ '' Wide

Treads with hard brass (delta metal) base of almost any desired width, may be made from our standard widths as indicated above.

The 2-inch deep nosing (Fig. 13) is designed expressly for use with cork composition, Karbolith flooring and concrete.

BRASS NOSINGS

The brass nosing pieces, shown in the cross section figures 15 and 16, are for use in connection with flat strips of Mason Safety Tread. These have been used with cork composition, as shown in the picture on page 12.

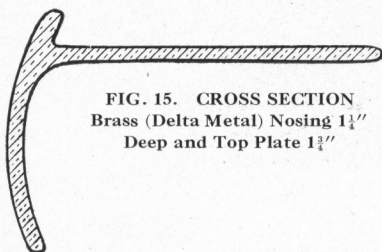

FIG. 15. CROSS SECTION
Brass (Delta Metal) Nosing $1\frac{1}{4}$ ''
Deep and Top Plate $1\frac{1}{4}$ ''

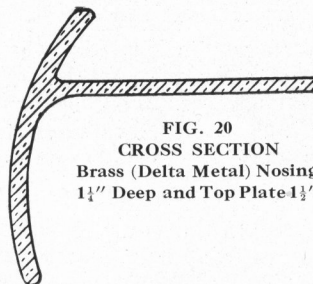

FIG. 20
CROSS SECTION
Brass (Delta Metal) Nosing
 $1\frac{1}{4}$ '' Deep and Top Plate $1\frac{1}{2}$ ''

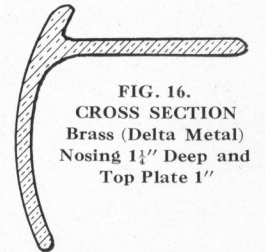

FIG. 16.
CROSS SECTION
Brass (Delta Metal)
Nosing $1\frac{1}{4}$ '' Deep and
Top Plate 1''

Brass nosing (Fig. 20) has a somewhat deeper top flange, and is used for tile, concrete and Karbolith treads.

MASON SAFETY TREAD ON WOOD

When applied to wood stairs Mason Safety Tread may be set in a rebate or sinkage, or placed on top of the stair tread, as indicated in the cut below. It furnishes adequate protection against slipping, increases the life of the stair many times, and materially strengthens it. When there is a sufficient width of tread, about two-thirds width of the step, no rebating is necessary. When backed with our cork composition, as shown on pages 11, 12, 13 and 14, the Mason Safety Tread should be placed upon the top of the stair tread.

This combination is highly approved for colleges, schools, churches, department stores, hotels, restaurants, saloons, etc.

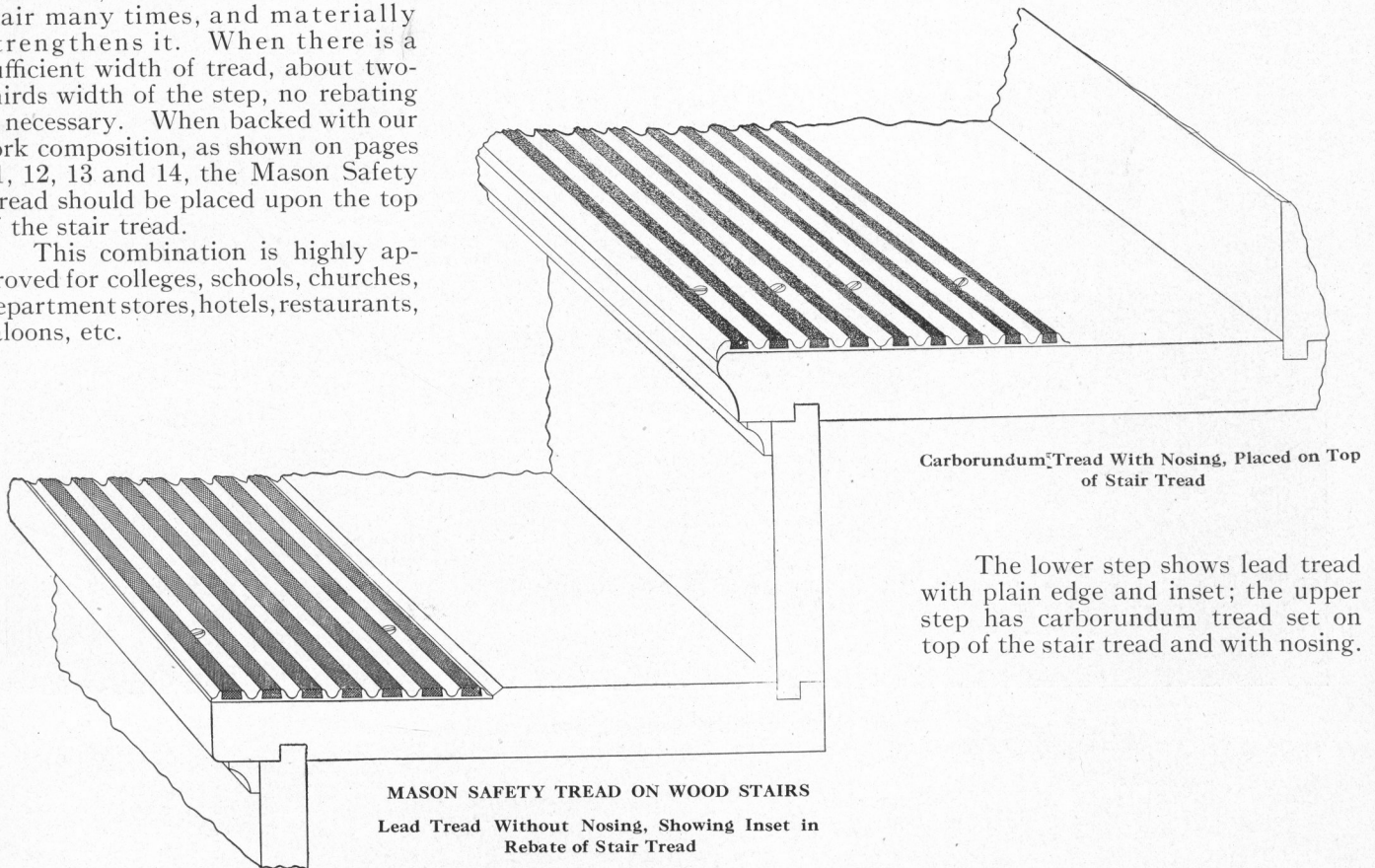

MASON SAFETY TREAD ON IRON

When applied to iron stairs, the best and most finished job is obtained by having the stair tread rebated to receive the Safety Tread, as shown in the engraving on this page, although it is frequently placed on the surface for both new and repair work, and equally good results are obtained.

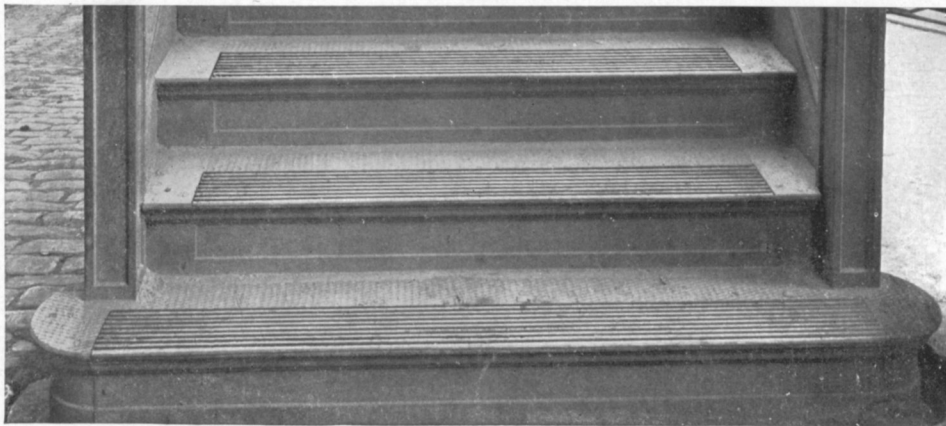

MASON SAFETY TREAD ON IRON STAIRS

All iron stairs should be protected by Mason Safety Tread, for otherwise the surfaces quickly polish and become dangerous. In frosty or damp weather they gather moisture, which adds to their slipperiness. Ice and snow do not adhere to the Mason Safety Tread; mud or grease only tends to increase its resistance to the foot, and changes of temperature have no effect upon it.

Exceedingly good results have been obtained by using Mason Safety Tread and a backing of Cork Composition on iron stairs and landings, as shown in the engraving on page 12.



LEWIS & CLARK HIGH SCHOOL, SPOKANE, WASH.
 All the School Buildings of Spokane Are Equipped with Mason Safety Tread.

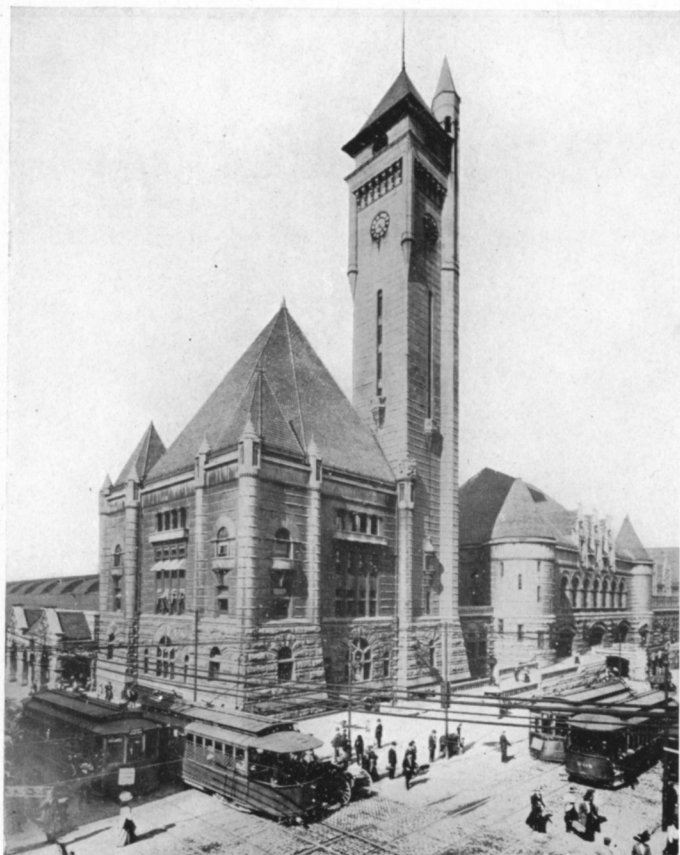

UNION STATION, ST. LOUIS, MO.



SOUTHWESTERN TELEGRAPH & TELEPHONE COMPANY
 BUILDING, HOUSTON, TEX.

Mason Safety Tread Installed in These Buildings

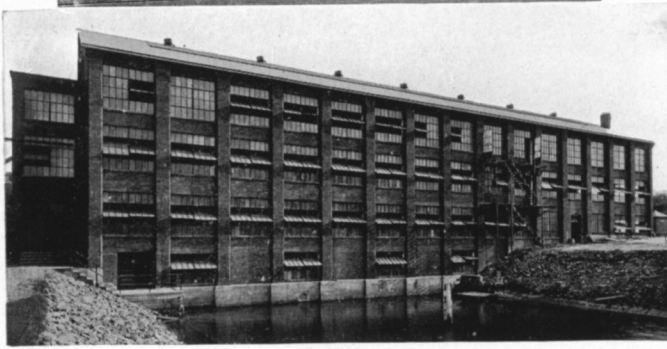
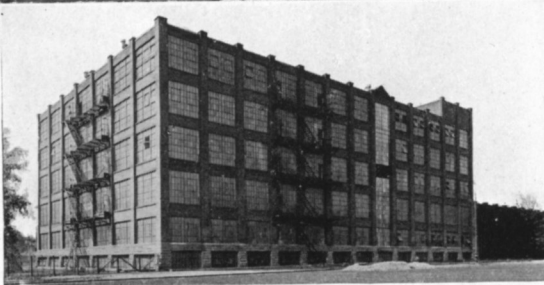
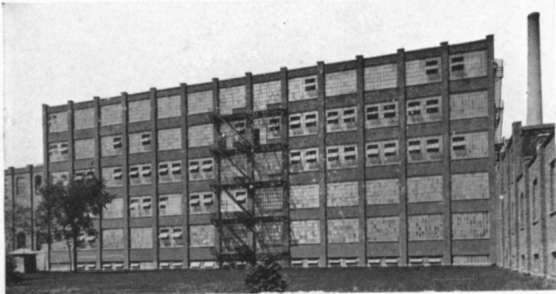

EASTMAN KODAK COMPANY'S KODAK PARK WORKS, ROCHESTER, N. Y.



BON MARCHÉ, SEATTLE, WASH.



TERMINAL AND ARCADE BUILDINGS, OKLAHOMA CITY, OKLA.

Mason Safety Treads in These Buildings



SYNDICATE TRUST COMPANY, ST. LOUIS, MO.



MILWAUKEE FRUNKWITZ, MILWAUKEE, WIS.

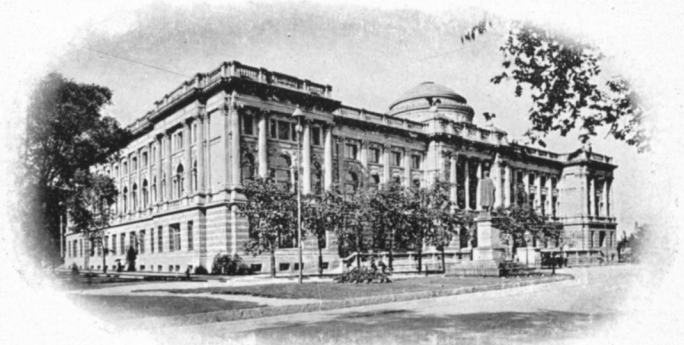

PUBLIC LIBRARY AND MUSEUM, MILWAUKEE, WIS.

MASON SAFETY TREAD ON STONE

On marble, granite and slate, many exceedingly fine effects have been produced, both with the lead-filled and the carborundum-filled tread. A large number of public and semi-public buildings have had Mason Tread installed on marble stairs, both for original protection and repairs. Among them are several of the stairways in the Capitol at Washington, D. C. The main stairway of the Suffolk County Court House, at Boston, has hard marble, and has been repaired with Mason Safety Tread steel base and carborundum; an engraving of it appears below.



MASON SAFETY TREAD (STEEL AND CARBORUNDUM)
Repairs on hard Italian Marble, Main Stairway, Suffolk County Court House, Pemberton Square, Boston, Mass.

The color of Mason Safety Tread harmonizes with the different shades of marble and looks well. Where hard brass (delta metal) is used, the effect on white marble or slate is excellent. It is readily applied and produces a perfectly rigid surface.

It is used to cover to within two or three inches of the rise of the step, and to within three or four inches of the baluster or skirting. Orders should state whether the material is to be placed upon the surface or in a rebate or sinkage, and also whether upon wood, iron, stone or cement.

MASON SAFETY TREAD ON CEMENT

On cement work Mason Safety Tread has proved a boon to the architect and builder, as in stair work the Safety Tread protects the edges from chipping, admitting the use of nosing or not, at the option of the architect, thus allowing the construction of square or round edges.

The inexpensive iron anchors are attached to the Safety Tread by ordinary machine screws, and the treads with anchors attached are bedded into the plastic cement. The iron strap, shown in the drawing on this page, is necessary only when the Safety Tread is composed of two or more sections.

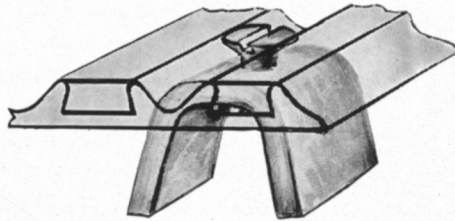

ATTACHMENT MASON TREAD TO ANCHOR

On inclined concrete sidewalks, as shown on pages 10 and 21, and at places where, for any reason, the surface is expected to be slippery, strips of Safety Tread are set in the cement at right angles with the curb, at the corners the strips being set fan-shaped or mitered. Some very fine effects have been produced in this way.

On concrete sidewalk lights, shown on page 21, strips are often run between every two sets of lens lights, the surface of the Safety Tread being brought flush with the concrete and glass. In these cases the Safety Treads will usually remain intact long after the surface of the concrete has required repairing.

The use of strips of Safety Tread laid on smooth iron, as shown on page 21, is quite common. The work is easily done, and the appearance of the walk is greatly improved. It is to be noted what good work can be done with curved strips, as shown on page 10.

The edge around concrete sidewalk lights is often treated in the same manner, or the surface paneled by strips of Safety Tread.

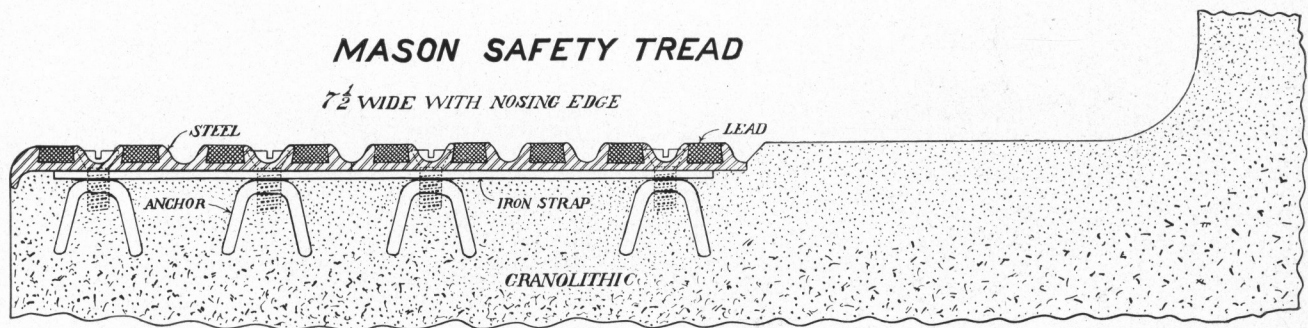

SECTION A--B.

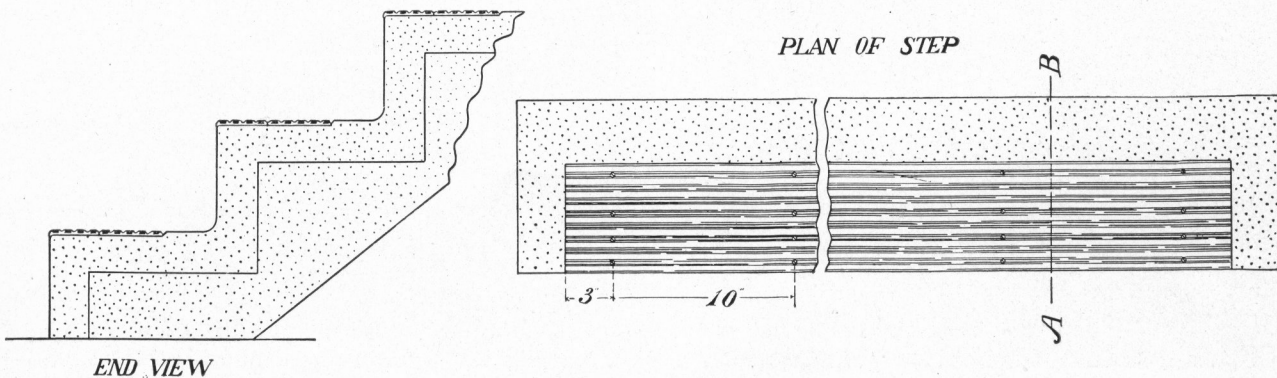

CROSS SECTION OF A GRANOLITHIC STEP, SHOWING ANCHORS AND IRON STRAP
Scale of Section A-B, 6 inches to the foot



MASON SAFETY TREAD (STEEL AND CARBORUNDUM) ON INCLINED GRANOLITHIC SIDEWALK
at Longfellow Street in Dorchester, a suburb of Boston, Mass.

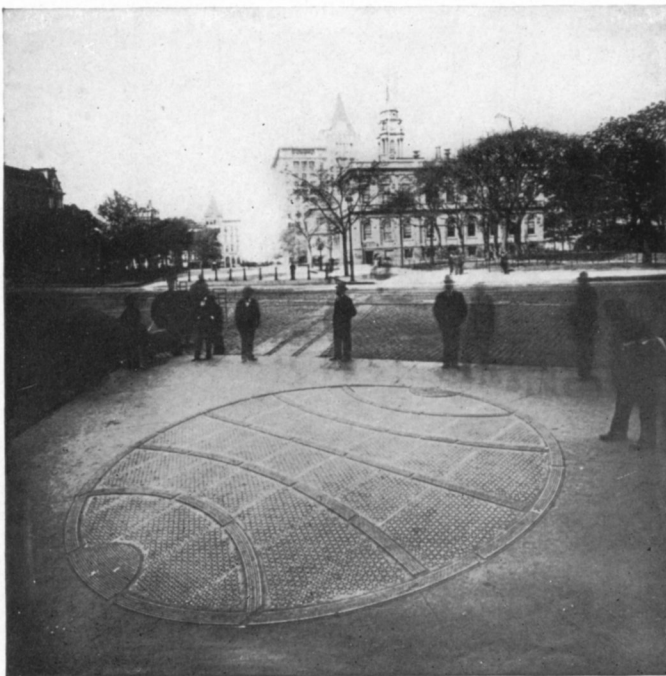

CURVED STRIPS OF MASON SAFETY TREAD ON SIDEWALK LIGHTS.



CURVED STRIPS OF MASON SAFETY TREAD ON WOOD STAIRS.

MASON SAFETY TREAD AND CORK COMPOSITION

This is a combination we have used for many years in special cases; it has been thoroughly tested and found satisfactory as to efficiency and durability. The cork composition is a peculiarly tough and springy product, of the same thickness as the Safety Tread. We first made the combination for a dry goods store to cover a long inclined corridor over which thousands of customers pass daily, and after a number of years, it is still in use and in excellent condition. It is made up of alternating strips of Safety Tread and Cork Composition. See line drawing on page 12.

The combination has been used by the Interborough Rapid Transit Company of New York, the Long Island Railroad Company of Brooklyn, and other railroads, for vestibules for their steel cars. The officials of the roads adopted this material only after a careful study of rubber and other devices available, and satisfactory proof of its superiority. A line drawing showing this material as installed on the steel cars of the New York Subway is shown on page 15.

For interior stairs and landings, in department stores, churches, schools, colleges, convents, dormitories, apartment houses, restaurants, cafes, hotels, theaters, society buildings, halls and club houses, this combination is desirable. The method is to place a single strip of any desired width of Safety Tread (preferably Fig. 5, page 3) on the front of the stair where the heaviest wear comes, and cover the remainder, or to within two or three inches of the riser, with cork composition. See line drawing, full size section, on this page.

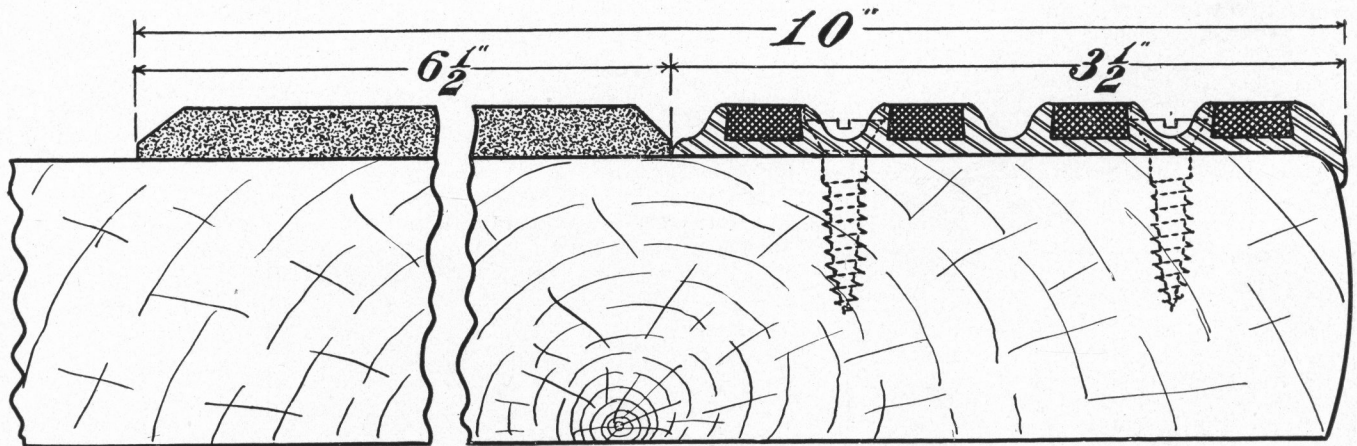

Three and a Half Inches in Width, Lead Filled Tread with Nosing and 6 1/2 Inches Backing of Cork Composition

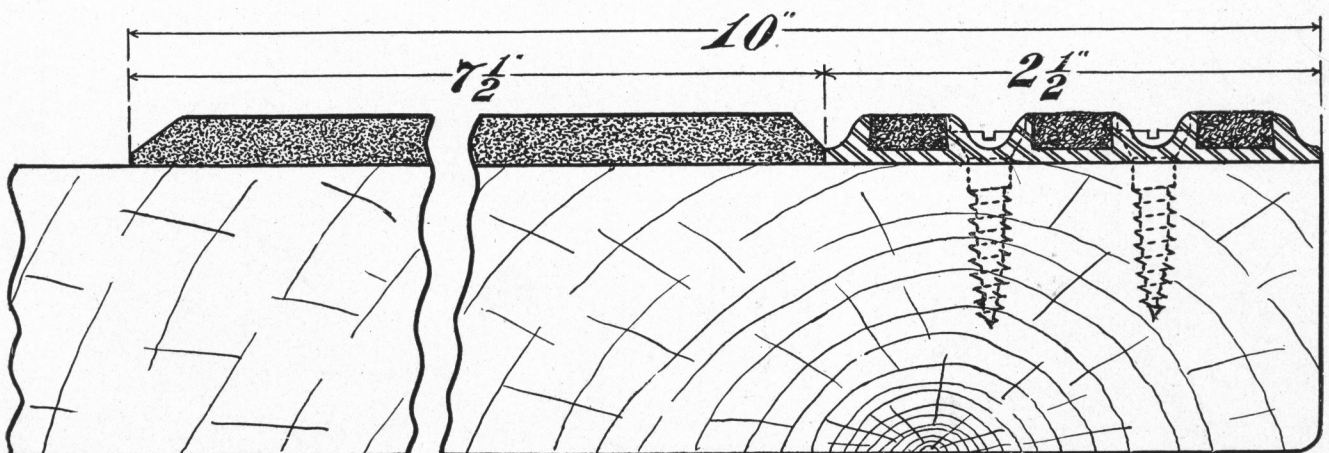

Two and a Half Inches in Width, Carborundum Filled Tread with Straight Edge and 7 1/2 Inches Backing of Cork Composition
FULL SIZE CROSS SECTIONS MASON SAFETY TREAD AND CORK COMPOSITION ON WOOD

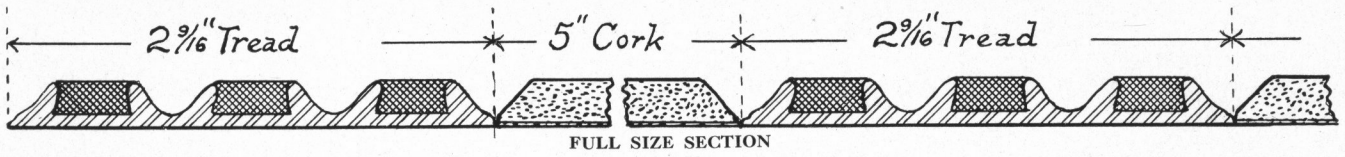

Alternating strips of Mason Safety Tread and Cork Composition for use on inclines.
 For landings a 3" square back with nosing, Fig. 5, page 3, may be used on the front edge.

The main stairway of the Emery-Bird-Thayer Co.'s big department store in Kansas City, Mo., a picture of which appears on this page, has Mason Special Brass Nosing (see Fig. 16, page 4) backed by cork composition, covering both tread and riser.



For inclined ways, ramps and elevator floors, the combination of Tread and Cork Composition makes an ideal flooring, the bulk of the wear being taken by the Safety Tread, the whole surface being easy to the foot and non-slippery.

EMERY-BIRD-THAYER COMPANY, KANSAS CITY, MO.
 Department Store



MASON SAFETY TREAD AND CORK COMPOSITION ON IRON STAIRS AND LANDINGS
 Houghton & Dutton Co., Department Store, Boston, Mass.

COMBINATION MATS

MASON SAFETY TREAD AND CORK COMPOSITION, IN MOVABLE SECTIONS

The floor around revolving doors receives a concentrated traffic and quickly shows wear; when the doors are removed, in the summer, these worn parts detract from the appearance of the entrance. This is particularly so where the vestibule is paved with marble. It is also true that the one passing through ordinarily makes a partial turn, following the general movement of the partition in front of him; this increases the danger of slipping and falling within the narrow confines of the section, making the risks proportionately greater. These sections should be supplied with a non-slippery floor. Our combination mats meet all the requirements of this situation. They are made in four quarter sections, thus permitting them to be readily removed for cleansing purposes.

The sections are interchangeable and admit of their being shifted so that the wear may be equally distributed. An extra quarter section should be carried on hand to be used, should it be necessary to return one of the sections to the factory for repairs. They can be removed entirely during the summer months when the revolving doors are out of service.

The picture of an entrance installed in the above manner, shown below, is lined from a photograph of one of the entrances with revolving door of the Hotel Astor in New York, the combination being composed of Cork Composition and hard brass (delta metal) base, lead filled Mason Safety Tread. The delta metal, which is about the color of 14 Carat gold, and the Cork Composition backed by the marble, gives a decidedly artistic effect.

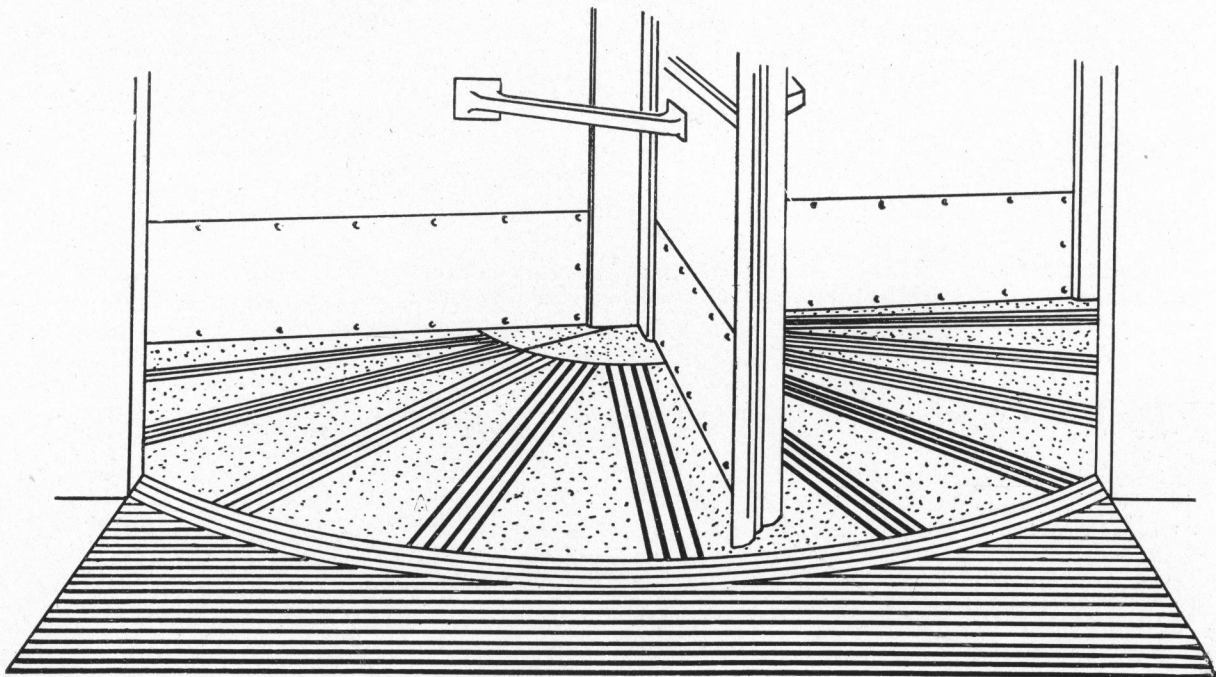

REVOLVING DOOR, HOTEL ASTOR, NEW YORK. COMBINATION INTERCHANGEABLE MATS

The combination of Mason Safety Tread and Cork Composition in the form of mats has been extensively used on some of the railroads for vestibules of cars. The alternating strips are firmly riveted to a heavy backing, and then the mats are fastened in place with screws. The officials of the roads adopted this device only after a careful study of rubber and other materials available.

REPAIRING WORN STAIRS

For repairing purposes, the combination of Mason Safety Tread and Cork Composition is without equal. Very badly worn stair treads are repaired by the method as shown on page 14, the worn portion being built up to the proper level by our Karbolith filling, on which the Safety Tread and Cork Composition rest, while all evidences of repair are concealed by a galvanized iron or handsome brass nosing.

The use of the combination for repair work is extensive and rapidly growing. The width of the Safety Tread is determined by the worn condition of the steps; where the edge is but little worn a 2½, 3, 3½ or 4-inch Safety Tread is often sufficient. The 3-inch piece with nosing, with square back (Fig. 5, page 3), is made expressly for this combination.

One of the finest examples of repair work by this method is upon the marble stairs leading to the gallery of the New York Stock Exchange. The front strip of Safety Tread, with polished hard brass base, backed by Cork

Composition, makes a showy contrast with the white marble. The Wheat Pit of the New York Produce Exchange is another example; in this case it is a flight of circular stairs, with Safety Tread on the edge, backed by the Cork Composition.

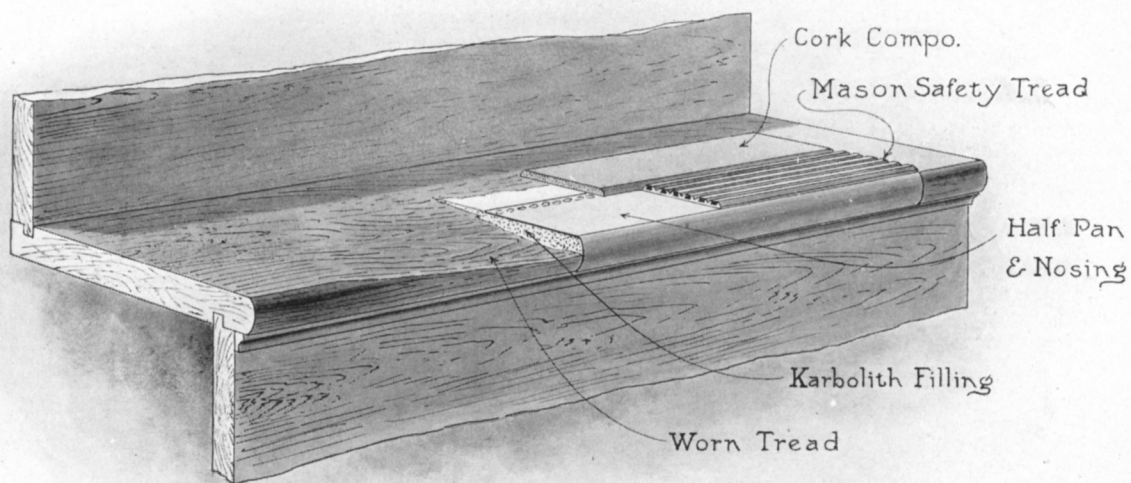

METHOD OF REPAIRING WORN TREADS BY USE OF MASON SAFETY TREAD, KARBOLITH AND CORK COMPOSITION

Our long experience in this work enables us to give directions for the successful repair of any stairway, no matter of what material or how badly worn. We are always pleased to furnish suggestions, sketches or blue prints, showing just how the work can be done best and at the lowest cost.



Before Repairing
MASON SAFETY TREAD, KARBOLITH AND CORK COMPOSITION REPAIR WORK ON WOODEN STAIRS AT THE ST. JOSEPH'S CATHOLIC COLLEGE, LOWELL, MASS.
 After Repairing

MASON SAFETY TREAD FOR RAILROADS

Transportation offers the greatest chances for accidents of almost any business, and not least among these are those due to slipping on station stairs and landings, and on car steps, platforms and vestibules. The foremost railroads have taken this matter up, and have installed, or are installing, Mason Safety Tread at all points where passengers crowd or rush; many stations have been or are being supplied with Safety Tread, as well as thousands of cars.

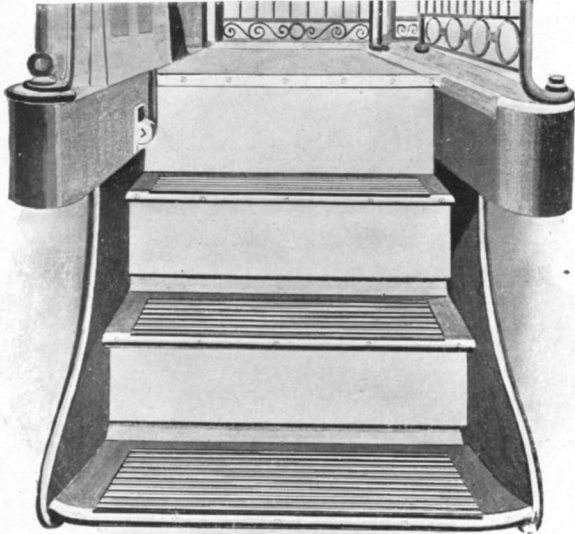

MASON SAFETY TREAD ON STEAM CAR STEPS

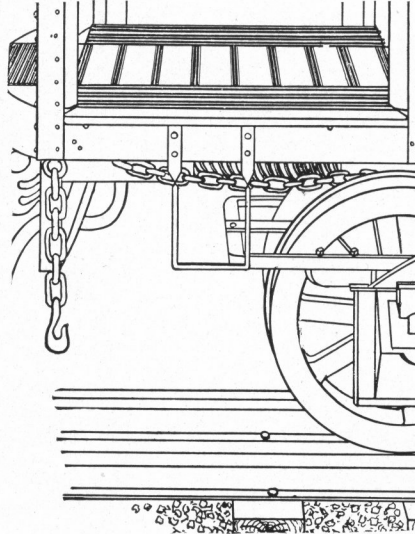

Sketch showing end of New York Subway Car with Mason Safety Tread and Cork Composition in Vestibule

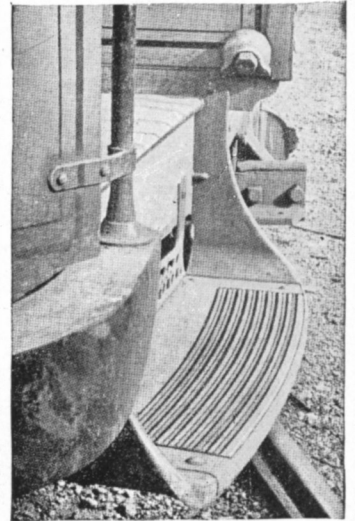

CURVED OR STRAIGHT TO FIT STREET RAILWAY CAR STEPS

Among the list are the great terminals of the Pennsylvania in New York and Philadelphia, of the New York Central in New York, and at Albany, the South Terminal at Boston, the Subways and Elevated Stations in Kansas City, Mo., Baltimore, Omaha, Peoria, the Central at Cincinnati, the Brooklyn Bridge, the Missouri Pacific at St. Louis, Kansas City, Mo., and hundreds of others. Scores of companies, including the Pullman Palace Car Co., the principal elevated and subway companies, and a large number of traction companies have installed Mason Safety Tread on car steps and platforms. The cheap tread originally put down at the new Worcester Station is being replaced by Mason.



MASON SAFETY TREAD, STEEL AND CARBORUNDUM, SET IN CONCRETE STAIRS
State Street Station, Boston, Mass., Washington Street Tunnel



SOUTH TERMINAL STATION, BOSTON, MASS.
Largest traffic of any station in the World; over 38,000,000 passengers per annum. All Stairs Equipped with Mason Safety Tread

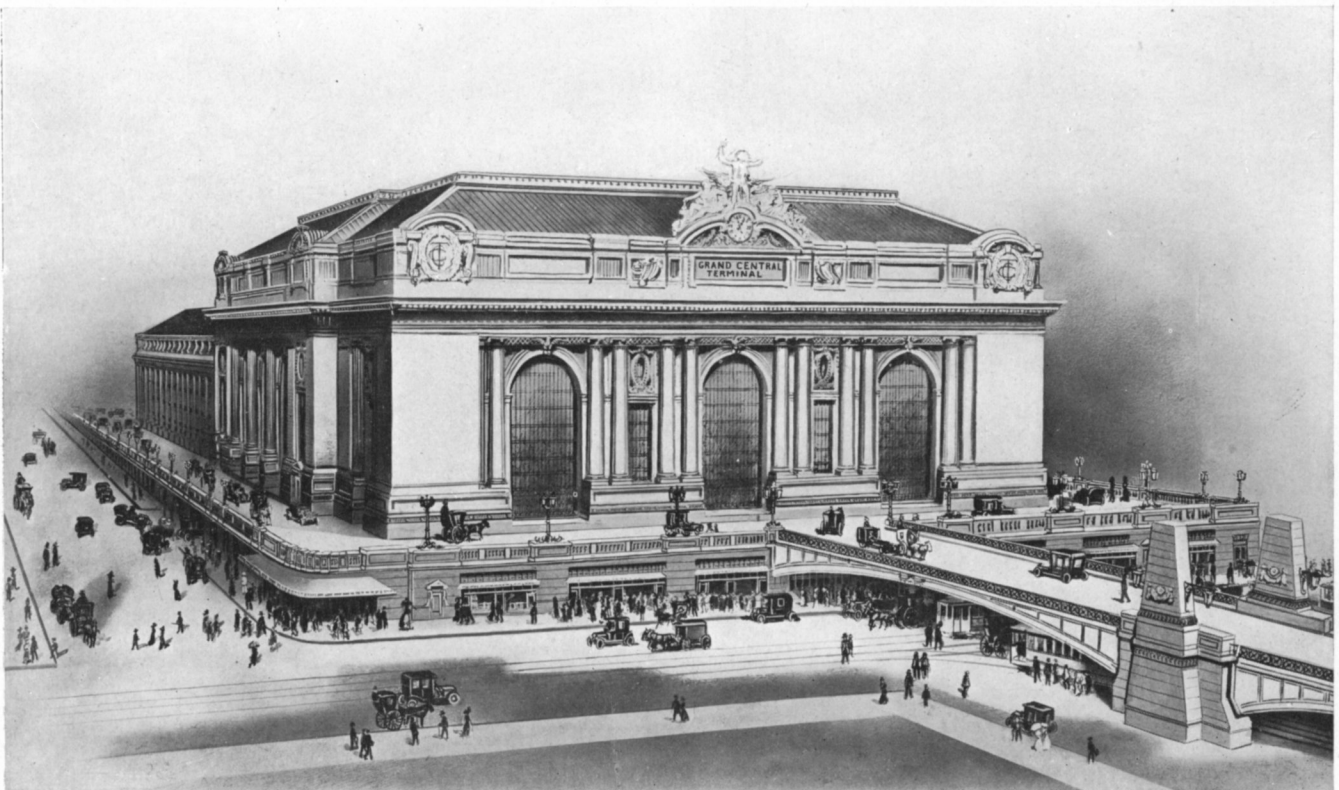

GRAND CENTRAL STATION, NEW YORK CITY
Mason Safety Tread Used



PENNSYLVANIA RAILROAD TERMINAL AT NEW YORK CITY
Mason Safety Tread Used

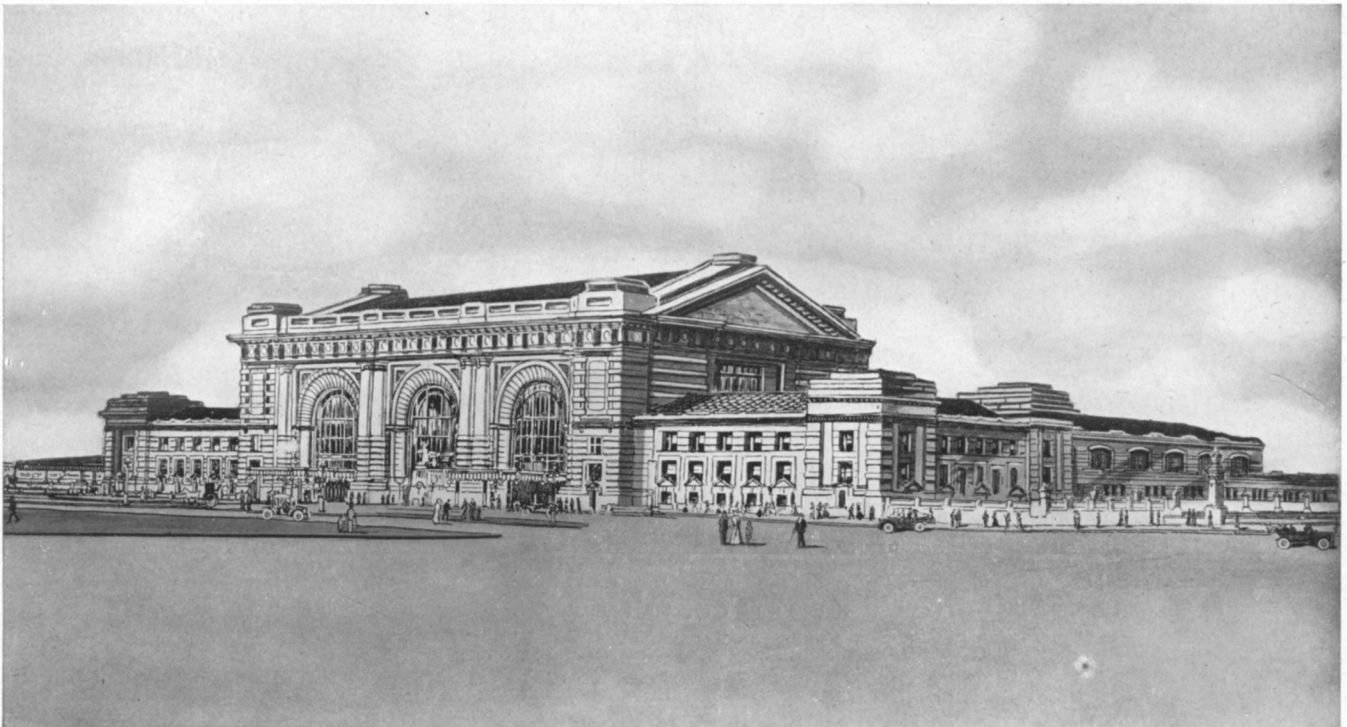

KANSAS CITY UNION STATION
Some 5,000 Square Feet Mason Safety Tread Used

MARINE

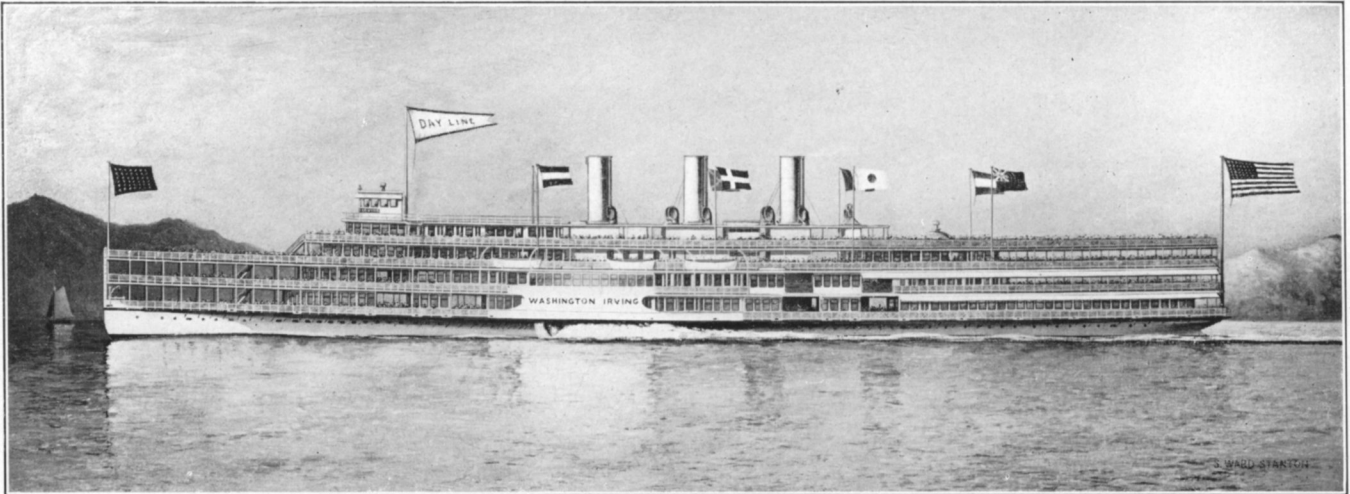

STEAMER WASHINGTON IRVING OF THE ALBANY DAY LINE;
for passenger service only; licensed to carry 6,000 people, the greatest number ever issued; framework steel and remainder of material non-inflammable.
MASON SAFETY TREAD installed on all stairways.

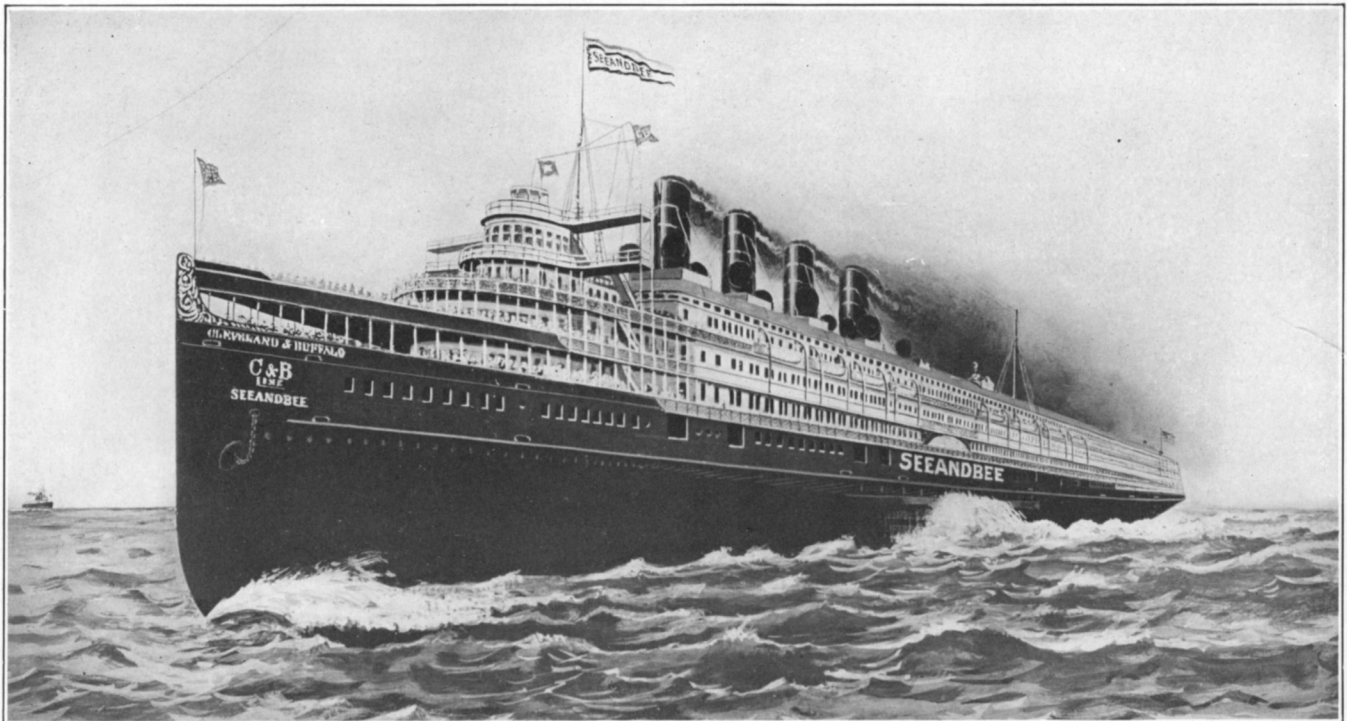

STEAMER SEEANDBEE;
500 feet long; licensed to carry 6,000 people; 1,500 tons freight; 6 decks; 12,000 horse-power engines.
MASON SAFETY TREAD installed on all stairways.

A majority of all the United States Naval vessels, including practically every battleship, cruiser and revenue cutter, is supplied with Mason Safety Tread, lead filled, delta metal base, for deck plates and steps, and at all points where protection from slipping is required, and the department is constantly calling for additional material of this nature. It has been found to successfully withstand the action of salt water.

MASON SAFETY VAULT LIGHTS

The distinguishing features of the Mason construction of vault lights are that it presents a level, non-slippery surface, and the maximum of light area to total surface consonant with the requisite strength and durability. It is so constructed that the lenses do not shiver and crack from contraction and expansion, these being provided for in setting both the panels and lenses. Repairs are easily made and lenses replaced without injuring the appearance of the surface. These conditions seem to be possible only with an all-metal construction. The surface is made non-slippery by the introduction of grooves or rebates filled with lead and by placing Mason Safety Tread in sinkages upon the border frames and panels.

The lenses are 2 x 3 inches in size, and the metal is placed where it will do the most good, and the whole structure is remarkably strong. I-beams should be placed 4 inches below the finished grade, and not more than 2' 10" O. C. for panel supports. The joints are watertight, and are not liable to get out of order.

The Mason Safety Vault Light has been specified by some of the best architects in the United States, and has been in use a sufficient length of time to prove its superiority over all others.

The Colonial Theater Building, Boston, vault light, covering the entire street area, was installed in 1900, and has been entirely satisfactory; although under part of it is the boiler room, which subjects it to a very severe test, no leaks have been developed.

The Easton Building vault light was installed in 1904, and continues to give complete satisfaction to the architects and owners. The panel vault light of the Suffolk Savings Bank is an excellent example of vault light in sections, as is that of the Minot Building, also of Boston. A few other examples are those of the Masonic Temple at Philadelphia, the Arcade Building at Philadelphia (a combination of Luxfer Prism and Mason Vault Light construction), Merchants and Mariners Building, also at Philadelphia, the Deseret News Building, Salt Lake City, the New England Trust Building, the Hornblower & Weeks Building, and the new Commonwealth Trust Building (see page 20), and the Boston Safe Deposit & Trust Company in Boston.

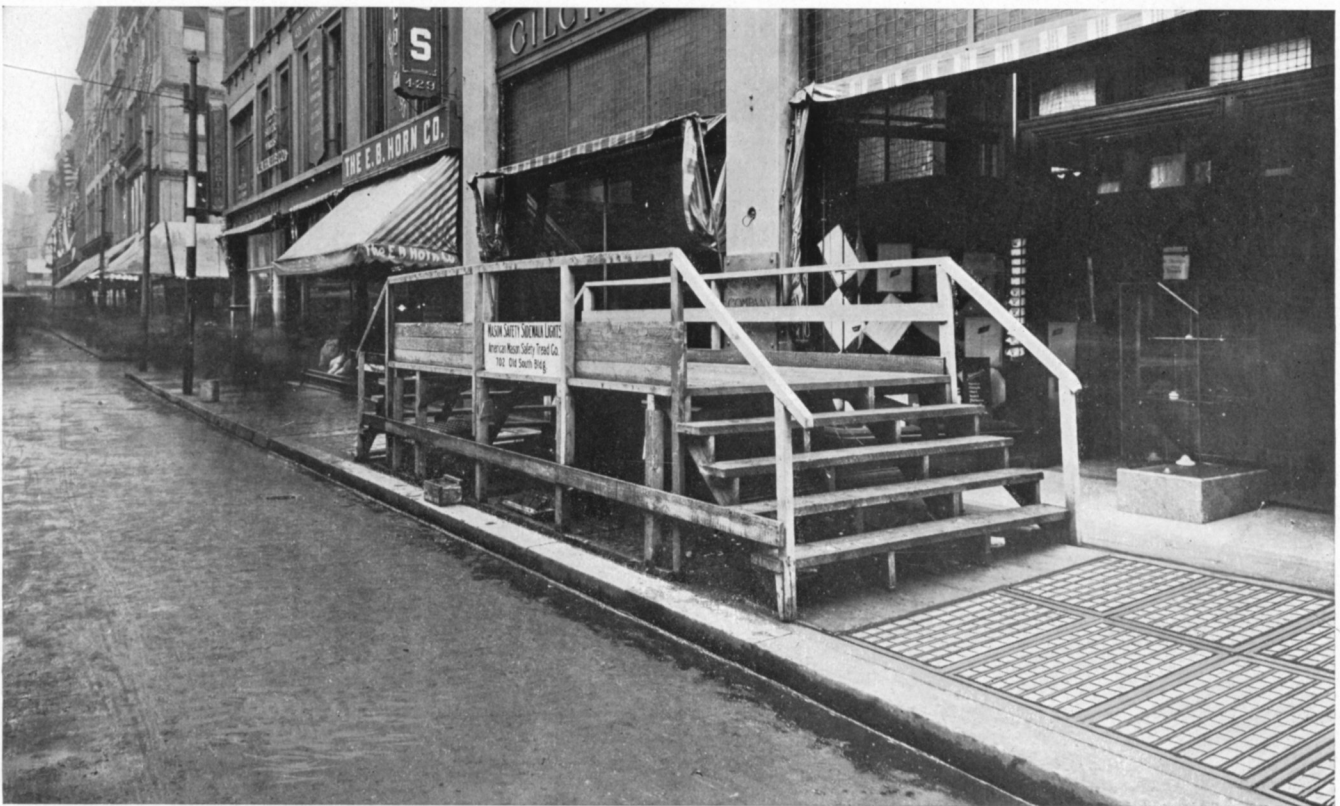

METHOD OF INSTALLING MASON SAFETY SIDEWALK LIGHT WITHOUT INTERRUPTING PUBLIC TRAFFIC OR INTERFERING WITH FREE ACCESS TO THE STORE

Our method of installing sidewalk vault light is shown above. In this, as in all other cases when necessary, we used a movable bridge for sidewalk traffic, and thus left a clear passageway to the entrance. At the right of the picture the panels have been placed, but the bordering strips of Mason Safety Tread have not been installed. At the left the work of removing the old vault light progresses beneath the bridge. This work was done in the heart of the retail dry goods district of Boston.



MASON SAFETY SIDEWALK LIGHT
Commonwealth Trust Company, Boston, Mass.



MASON SAFETY SIDEWALK LIGHT ASH LIFT COVER (OPENED)
New England Trust Company, Boston, Mass.

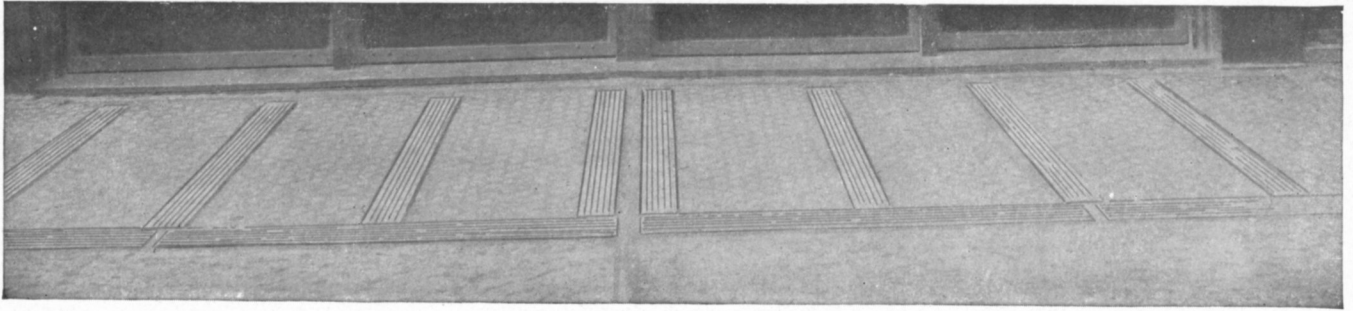

MASON SAFETY TREAD ON SMOOTH IRON

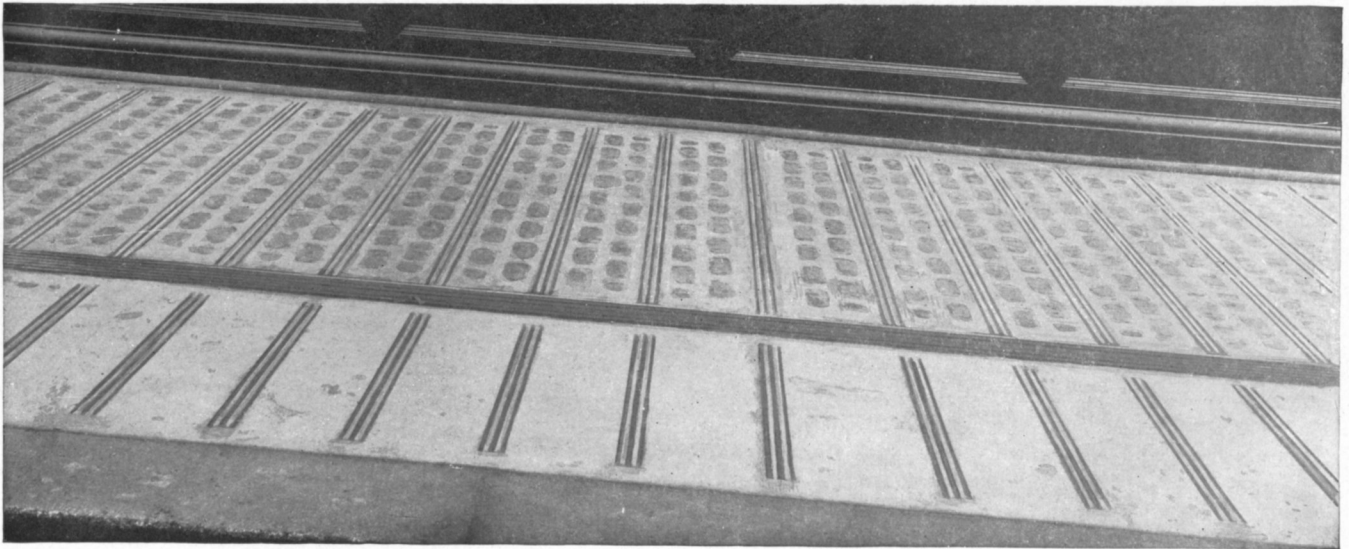

SAFETY TREAD STRIPS BETWEEN LENSES
In Cement Vault Light on an Inclined Walk, and in Cement Sidewalk from Vault Light to Curb



ROGERS HOTEL, MINNEAPOLIS, MINN.
Marble Stairway, Brass (Delta Metal) Base, Mason Safety Tread Used



McKINLEY MANUAL TRAINING SCHOOL, WASHINGTON, D. C.
Main Stairway, Treads and Risers $\frac{1}{2}$ Inch Thick, Karbolith with Lead Filled
Mason Safety Tread on Front Edge

THE STANWOOD TREAD

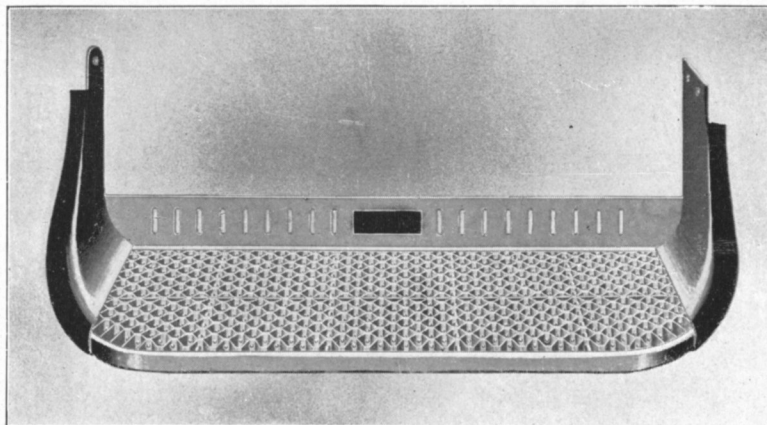

STANWOOD CAR STEP

This tread is made up of a number of thin strips of high carbon steel, bent so that when assembled they form a series of openings in the surface of the tread, as shown.

The Stanwood tread is exceedingly strong and serviceable, and is especially adapted where cleanliness and safety are important features, such as on stairways to engine rooms, areaways, etc. It was originally designed for use on Street Railway and Steam Railroad Cars, and was adopted by a large number of roads on account of its non-slipping and self-cleaning features. It has been used for years in the above service and has proved itself most efficient.

Stanwood treads are made to order in any size and shape desired. We have a special department for this work, and are thus in a position to fill all orders promptly.

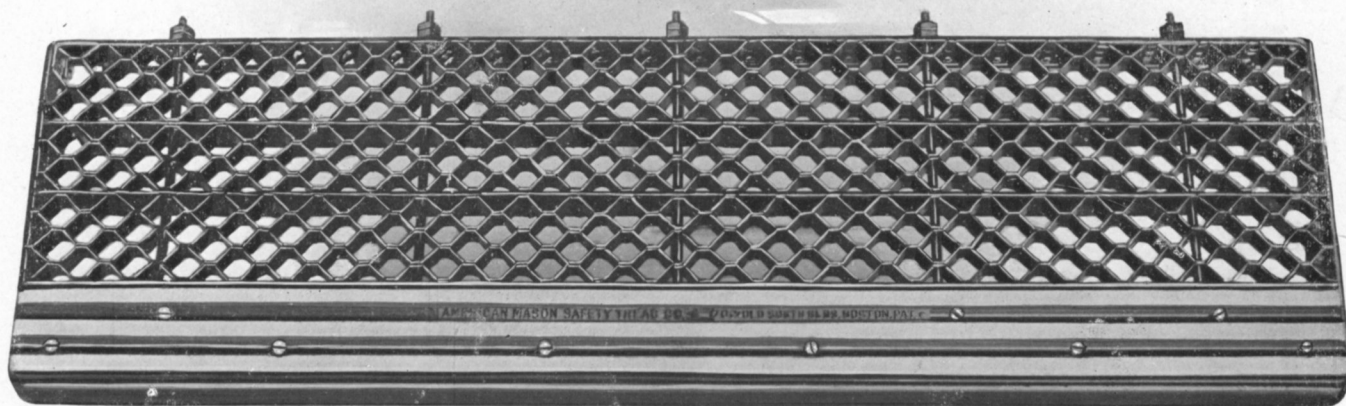

STANWOOD-MASON STEP

We also make a Stanwood tread with a strip of Mason Safety Tread along its front edge. This is known as the Stanwood-Mason tread. This type of Stanwood tread embodies an added safety feature which in many cases is desirable.

IMPORTANT IN ORDERING STANWOOD STEPS

Stanwood Steps cannot possibly be carried in stock, but are, of necessity, made to order according to dimensions furnished.

A dimension sheet carefully filled in should accompany each order, that the steps may be correctly made to accurately fit the cars on which they are to be used.

Blank dimension sheets will be furnished upon application. Correct dimensions in the first instance save vexatious delays.

STANWOOD STEPS are made right and left hand, and it should always be stated whether or not the sketch or dimension sheet shows a right hand or left hand step.

A right hand step is the one to the right of the motorman as he stands when running the car.

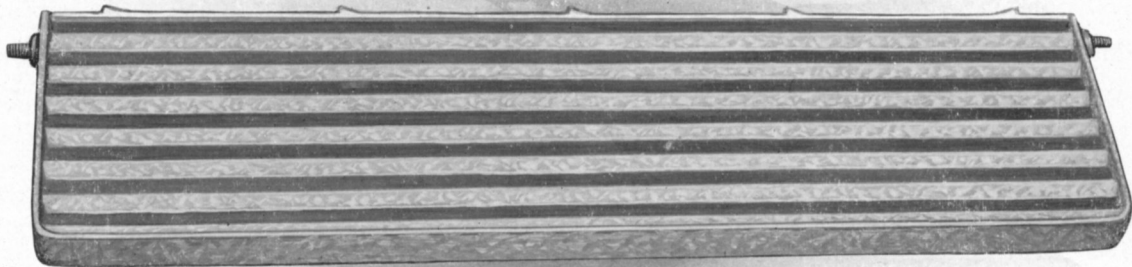

MASON SAFETY TREAD, ON STANWOOD FRAME, FOR LADDER STEP

KARBOLITH FLOORING SANITARY COVE BASE AND WAINSCOTING

This material makes the best flooring for churches, hospitals, theaters, banks, stores, cafes, factories, power plants, bathrooms, libraries, billiard rooms, pantries, dining rooms, kitchens, etc.

For recovering old or new wood floors or surfacing concrete and cement it has no equal, as it gives a surface over which walking is easy and noiseless.

It is laid in a plastic state, and is therefore crackless.

No scrubbing is needed, as with wood, hence it is the cleanest of all floors.

It is cheaper than floor coverings, as it requires no renewals.

It is fireproof, being composed almost entirely of magnesium compounds.

It is proof against fire, germs and rats.

It has been installed in hundreds of public and semi-public buildings, hotels and restaurants, railroad stations, hospitals, private residences, large department and other stores, schoolhouses, theaters, churches, manufacturing plants, garages, etc.

Send for special catalogue on Karbolith.

CAR KARBOLITH

This is a special composition prepared by this company for car flooring and is extensively used on steel cars, as it binds firmly to a metal base, and withstands the shock and strain of rolling stock better than any other composition flooring.

Among the railroad companies which are using Car Karbolith on their steel cars are the Pennsylvania, the Baltimore & Ohio, the Interborough Rapid Transit Co., the Hudson Terminal companies, the Long Island, New York Central & Hudson River, New York, New Haven & Hartford, Chicago Railways, Philadelphia & Western, New York & Queens County Railway, Philadelphia Rapid Transit Co., the Boston Elevated Railway, and many others.

WHERE ACCIDENT POLICIES DO NOT INSURE

We respectfully suggest to manufacturing concerns and others, employing a large amount of labor, that they equip the stairs of their mills, factories and stores with Mason Safety Tread to prevent accidents. A few small strips around the engines and dynamos, on iron stairs, on any place where there is likelihood of grease or oil deposits, will greatly reduce the risk of slipping. Many companies insure in an accident insurance company, but the insurance company expects and demands that its policy holder shall do everything in his power that is reasonable to make the plant safe. The Accident and Liability department of the Aetna Life Insurance Company in their book "Safeguards" refers to the Mason Safety Tread as the proper device for dangerous stairs. Where our Safety Tread is installed and there is an accident, the Court invariably is convinced that there was no contributory negligence on the part of the employer, as he had used the best known precaution to prevent accident.

SPECIFY MASON SAFETY TREAD

Many of the prominent architects and engineers prepare their specifications as follows: "The treads of all stairs shall be provided with recess or rebate for and shall have applied to them Mason Safety Tread (lead or carborundum filled).....inches wide, and said Mason Safety Tread shall extend to within three inches of balusters or skirtings." **FOR MASON SAFETY SIDEWALK VAULT LIGHT.** "Provide and install the Mason Safety Sidewalk Light as shown on drawings. The I-beams for supporting the light to be 2 feet 10 inches O. C. The top of the beams to be 4 inches below finished grade of the sidewalk."

SOME REFERENCES

A FEW INSTALLATIONS OF MASON SAFETY TREAD TAKEN AT RANDOM FROM THE THOUSANDS THAT ARE TO BE FOUND IN NEARLY EVERY CITY IN THIS COUNTRY AND CANADA, AND NOT INCLUDING ANY ALREADY REFERRED TO IN THIS CATALOGUE

Baltimore, Md. Hospital for Insane; House of Correction; Sykesville and Spring Grove Asylums; Polytechnic Inst.; dep't stores of The Leader, Hochschild, Kohn & Co. and Hutzler Bros.; Rennett Hotel.

Boston, Mass. Dep't stores of C. F. Hovey & Co., Jordan Marsh Co., R. H. White & Co., Gilchrist Co., Shepard & Norwell Co.; throughout the business section everywhere; City Hall; all R.R. stations and terminals; on all Elevated Railroad, Tunnel and Subway stairs; in Telephone and Edison Co. buildings in city and suburbs; specified on all new work of the Boston Transit Commission; on commercial buildings like Walcott Co., Chauncy Hall School, Leopold Morse & Co., Boylston Market Association, D. Demmon Estate, Suffolk Real Estate, W. A. Gaston, W. H. Tucker, Aspinwall & Codman, Congress St. Associates, E. E. Gray & Co., Boylston Brewery, Diamond Rubber Co., Epstein Drug Co., Univ. Pub. House, Eclipse Mfg. Co., Harvard Medical School; Floating, Relief and other hospitals; Gale, Bradley & Tyson, Thompson's Spa, Gillette, Goddard, Franklin, Transcript, Wright & Ditson, United Cigar Stores Co., Old South and hundreds of other buildings.

Brooklyn, N. Y. Hotels St. George and Clarendon; the Jockey and Brooklyn Clubs; schools of St. Agnes, St. Teresa, St. Patrick, St. John the Evangelist, St. Vincent de Paul, St. Peter's, Erasmus Hall High; Abraham & Straus, Frederick Loeser & Co., A. D. Mathews Sons, A. I. Namm & Son, The Boston, The Berlin, all Bristol dining rooms, Kings Co. Hospital, Bush Terminal Factories, Mergenthaler Linotype buildings, U. S. Marine barracks, National City Bank, Robert Gair Co., The Standard, American Manufacturing Co.

Buffalo, N. Y. Public Schools, Technical High, St. Ann's Church and School; Woolworth Co.; German Orphan Asylum; Bell Telephone Co.; Iroquois Hotel; The Larkin Co., J. N. Adams Co., Wm. Hengerer.

Chicago, Ill. R.R. Stations including the Union, La Salle St., Ill. Central, Union Elevated, South Side Elevated, C. & N. W., C., M. & St. Paul, C., R. I. & P., C. & E. Ill., Dearborn, Soo Line Freight Terminals; department stores of Marshall Field & Co., Mandel Bros., The Fair, The Boston, Rothschild & Co., Siegel, Cooper & Co., W. A. Wieboldt & Co., E. Iverson & Co., Carson, Pirie, Scott & Co.; hotels Palmer, Stratford, Kaiserhof, Planter, Rectors, North American, German Rathskeller, Boston Oyster House, Henricis, Heinely's, Vogelsangs and the Bismarck; packing plants, Union Stock yards, Swift & Co., Sulzberger & Sons Co., Armour & Co., Hammond Co.; office buildings, Peoples Gas, New Lytton, Consumers, North American, C., B. & Q. R.R., Fort Dearborn, Pullman, American Trust, Jos. T. Ryerson & Son, a dozen or more United Cigar Stores; practically all 5 and 10 cent stores of F. W. Woolworth Co., S. H. Knox & Co., S. S. Kresge & Co.; all elevated and surface lines; Reid Murdoch & Co., Steele, Wadeless & Co., Sears, Roebuck & Co., Montgomery, Ward & Co., The Norwegian Lutheran and University hospitals; the City Hall and Court buildings; the Chicago and the Illinois Athletic Clubs.

Cleveland, Ohio Dep't stores, Sterling & Welch, The May Co., The Higbee Co., Richman Bros. Co., The Bailey Co.; Steamers "Victory" and "McDougall";

Cleveland Knitting Mills, Standard Welding Co., Chandler & Rudd Co. (3 stores), Hoffbrau Cafe; Public Library, 4 comfort stations, City Hospital; Nickel Plate depot, Euclid Heights High School; Stadler and Hollenden hotels; Williamson building and Osborn Mfg. Co.; Masonic Temple, Dangler Stove Co., Upson Nut Company, Hart Mfg. Co., Crowell & Hubbard, Richmond Bros. Co., W. S. Gilkey Ptg. Co., Northern Ohio Blanket Mills, Geo. Worthington Co., United Cigar Stores Co., Printz Biederman Co., Raugh & Lang Co., Lake Shore depot.

Denver, Colo. Auditorium, Denver Dry Goods Co., City Bath House; N. D. High, Corona, Manual Training, Aaron Grove, R. W. Steel, Garden Place, and many other schools; Majestic Theatre, Standish Hotel, Y. M. C. Assn., K. of C. buildings.

Houston, Texas Home and Southwestern Telephone buildings; Southern Pacific office, Commercial Bank; Rusk, Crockett and Longfellow schools; Cotton Hotel; M. K. & T. new passenger station.

Kansas City, Mo. Stock Exchange, Loose Wiles C. & C. Co., Sears, Roebuck & Co., John Taylor Co., Jones Store Co., Woolworth Co., Convention Hall, Board of Trade, First National Bank, Merry, Burnham, Munger, Root Co. (factory and wholesale buildings), Smith, McCord Co.; Manual, Central, Westport, North East, Lincoln high schools, and 26 ward schools; Jackson County Court House, Poor Farm and Jail; City Hall; Fire headquarters and 14 sub stations, F. A. Long, Altman and Hewson office and Star and Journal newspaper buildings.

Minneapolis, Minn. 13 school and 8 university buildings; Minn. Loan and Trust, N. W. National Bank; hotels West, Hastings, Oneida, Rogers, Radisson and Vendome; Y. M. C. Assn., Post Office, City Hall and Court House; Glass and Kasota blocks; Plymouth, Rassler, N. Y. Life, Twin City Cold Storage, Minn. Brewing Co., Powers and Minn. Dry Goods, Libby & Libby I. W. Badger, Eagle and North Western Tel. Exchange buildings.

New York City 90% of Interborough and Brooklyn Rapid Transit Co.'s elevated and subway stations; on all Hudson Terminals and Tunnel; all Brooklyn bridges; N. Y. public schools, police stations and city docks; Chelsea piers, comfort stations, fire houses, steamship and buildings at Blackwells Island; Terminals and stations of the D., L. & W. R.R. Co., Jersey Central, N. Y. Westchester & Boston (all stations), Hudson & Manhattan Ry. Co., Erie, 5th Avenue Coach Co. and Yellow Taxi Cab Co.; hotels Plaza, Waldorf-Astoria, Astor, Knickerbocker, Astor House, Netherlands, Savoy, Walcott, Ritz-Carlton, Biltmore, Grand Union, St. Regis, Gotham, Holland, Rector; newspapers, Herald, World, Times, American, Mail & Express; Chesebrough, Western Union, Commercial Cable, Postal Telegraph, Adams Express, Silversmith, 42nd Street & Madison Ave., N. Y. Telephone Co. (26 buildings), Edison Co. (Duane Street and power plants); N. Y. Cotton and Stock Exchanges.

Omaha, Neb. Post Office; City National and State banks; Loyal and Rome hotels; Woodmen of the World; Nebraska Telephone and Brandies buildings, C., B., & Q. R.R. station.

Philadelphia, Pa. 90% of all elevated and subway stations; on all cars of the Philadelphia Rapid Transit Co.; on all stairs, where there are any safety treads, of the Broad Street Station Penn. R.R.; Phil. & Reading Terminals; hotels Bellevue-Stratford, Hanover, Betz Building Rathskeller, Dooner, St. James; Strawbridge & Clothier, Gimbel, John Wanamaker, Lit Bros., John B. Stetson, Union League, Stephen Girard; Bell Telephone, Masonic Temple, Athletic Club, Victor Talking Machine Co. buildings; Jefferson Medical College; University of Penn (6 buildings); Custom House, Jefferson Hospital; 51 fire and police stations, and a large number of schools.

Portland, Ore. East and West Side Pacific States Tel. & Tel. Co., Holtz Dept. Store; Odd Fellows', C. K. Henry, D. P. Thompson, Washington, Public Comfort Station, Oregon Agricultural College, Troy Laundry building.

Spokane, Wash. Old National and Union Trust & Savings banks; Hyde, Rookery, Empire State, Paulsen; Lindelle; New City Hall and Federal buildings; Kemp & Hebert Dept. store; Pennington Hotel and Davenport's restaurant.

Seattle, Wash. G. N. & U. P. Station, Hincley block; Independent Tel. and Pacific Tel. & Tel. Co., Amos Brown and Frederick & Nelson buildings.

Salt Lake, Utah L. D. S. University; Salt Lake High; Jefferson, Whittier, Riverside and Emerson schools; Union Station; Continental Bank.

St. Louis, Mo. Public Schools; State School for Blind; St. Louis Trust, Missouri Trust, Lincoln Trust, Commonwealth Trust, Third National bank; Chemical, Holland, Frisco, Pierce, Wright, Wall, The Famous; Nugent Bros., Brown Bros., Grand Leader St. Louis Post-Dispatch, Globe-Democrat, Republic, Star and Times; St. Louis Cordage Co., St. Louis Business College, McKinley System buildings; Planters, American, Moser, Lippes and McTague's hotels and cafes; American, Columbia and Olympic theatres; United Railways Co., American Car Co., Suburban Street Railway Co., Butler Bros., Ely-Walker Dry Goods Co., Scruggs-Vandervoort-Barney, Barr's and The May Co.; Board of Education.

San Francisco, Cal. Steamers New Western Pacific Ferry; U. S. A. transports "Logan" and "Thomas" and S.S.'s "Beaver" and "Bear;" cars of the United R.R. and Municipal Ry.; Emporium, Hale Bros. dept. stores; Standard Oil Co., American Can Co., Municipal Railway's car barns, Pumping Station, Ensign saloon, Harrison Street and P. G. C. North Beach play grounds; Philadelphia Shoe store, Walker Building; 4 Pacific Tel. & Tel. exchanges; 13 schools and colleges.

Washington, D. C. U. S. Court House, W. B. Moses & Sons, Woodward & Lothrop, S. Kann Sons & Co., Goldenberg, Parker & Bridgett, Franklin School, National Capitol Press, Kernan's Lyceum Theatre; Metropolitan and Army & Navy Clubs; Home Savings and Commercial National banks; Columbia Hospital; Bureaus of Standards and Weather; Palais Royal, both the old and new Masonic Temples.

MASON SAFETY TREAD

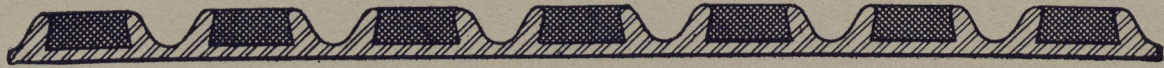

LEAD OR CARBORUNDUM FILLED



AMERICAN
MASON SAFETY TREAD COMPANY

LOWELL, MASSACHUSETTS